



A1080 and GeoHelix Antenna

**A description on using Sarantel's GeoHelix Antenna
With the GPS receiver A1080**

Application Note

**Version 1.1
Hardware Revisions 01, 02 and 03 (A1080)**

Revision History

Rev.	Date	Description
1.0	07-03-07	Initial draft
1.1	08-21-08	New style; moved to Vincotech
	mm-dd-yy	

Disclaimer

THIS DOCUMENT CONTAINS PROPRIETARY INFORMATION OF VINCOTECH GMBH. IT MAY NOT BE COPIED OR TRANSMITTED BY ANY MEANS, PASSED TO OTHERS, OR STORED IN ANY RETRIEVAL SYSTEM OR MEDIA, WITHOUT PRIOR CONSENT OF VINCOTECH OR ITS AUTHORIZED AGENTS.

THE INFORMATION IN THIS DOCUMENT IS, TO THE BEST OF OUR KNOWLEDGE, ENTIRELY CORRECT. HOWEVER, VINCOTECH CAN NEITHER ACCEPT LIABILITY FOR ANY INACCURACIES, OR THE CONSEQUENCES THEREOF, NOR FOR ANY LIABILITY ARISING FROM THE USE OR APPLICATION OF ANY CIRCUIT, PRODUCT, OR EXAMPLE SHOWN IN THE DOCUMENT.

THE PRODUCT (HARD- AND SOFTWARE) DESCRIBED IN THIS DOCUMENTATION IS NOT AUTHORIZED FOR USE IN LIFE SUPPORT DEVICES OR SYSTEMS WITHOUT THE EXPRESS WRITTEN APPROVAL OF VINCOTECH.

THIS DOCUMENT MAY PROVIDE LINKS TO OTHER WORLD WIDE WEB SITES OR RESOURCES. BECAUSE VINCOTECH HAS NO CONTROL OVER SUCH SITES AND RESOURCES, VINCOTECH SHALL NOT BE RESPONSIBLE FOR THE AVAILABILITY OF SUCH EXTERNAL SITES OR RESOURCES, AND DOES NOT ENDORSE AND IS NOT RESPONSIBLE OR LIABLE FOR ANY CONTENT, ADVERTISING, PRODUCTS, OR OTHER MATERIALS ON OR AVAILABLE FROM SUCH SITES OR RESOURCES. VINCOTECH SHALL NOT BE RESPONSIBLE OR LIABLE, DIRECTLY OR INDIRECTLY, FOR ANY DAMAGE OR LOSS CAUSED OR ALLEGED TO BE CAUSED BY OR IN CONNECTION WITH USE OF OR RELIANCE ON ANY SUCH CONTENT, GOODS OR SERVICES AVAILABLE ON OR THROUGH ANY SUCH SITE OR RESOURCE.

VINCOTECH RESERVES THE RIGHT TO CHANGE, MODIFY, OR IMPROVE THIS DOCUMENT OR THE PRODUCT DESCRIBED HEREIN, AS SEEN FIT BY VINCOTECH WITHOUT FURTHER NOTICE.

Table of Contents

1 Introduction	5
2 Schematics	5
3 Components and Layout Considerations	6
3.1 LNA Section	6
3.2 Power Supply Switch Section	6
3.3 Antenna.....	6
4 References	7
5 Related Information	8
5.1 Contact.....	8
5.2 Related Documents.....	8

1 Introduction

This document aims to highlight some consideration that should be taken into account when using GeoHelix antenna from Sarantel with Vincotech's highly sensitive GPS receiver module A1080.

2 Schematics

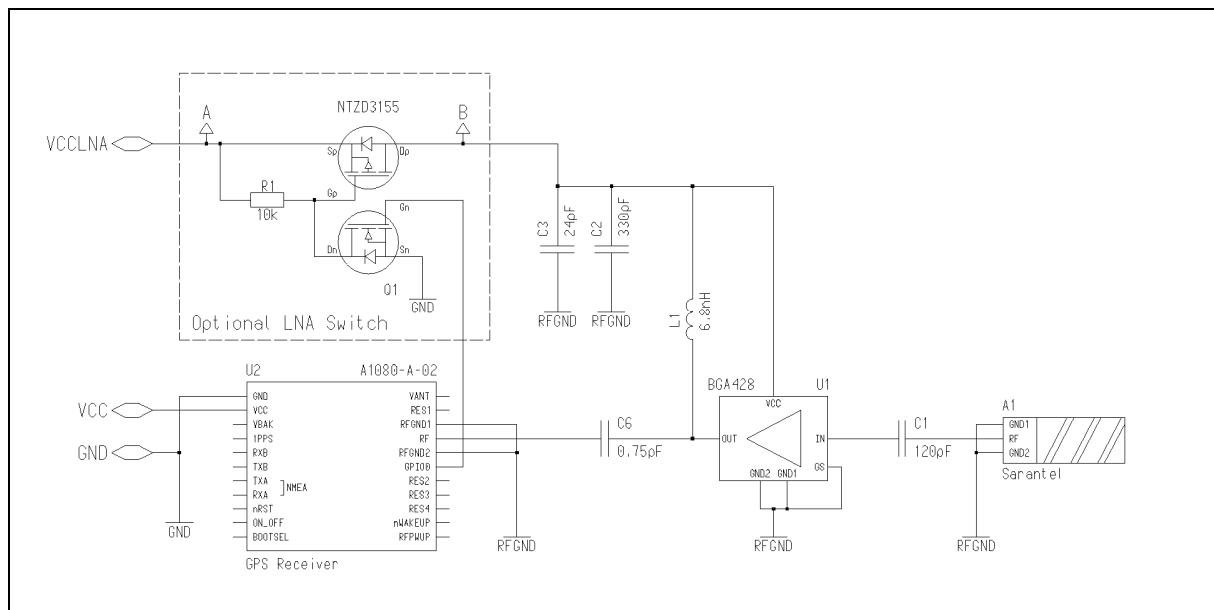

3 Components and Layout Considerations

3.1 LNA Section

For a detailed description and for recommendations regarding the components (C1, C2, C3, C6 and L1) used in the LNA design see the application note [2] provided by Infineon.

It is necessary to follow common RF design rules (line impedance, ground plane, separation of RF ground from digital ground, ...) in order to achieve best possible performance. See section 8.1 “Connection of RF Signal“ in the A1080 GPS Receiver manual. A good starting point for the LNA design is the reference layout shown in BGA428 application note [2].

However, depending on the actual design, some minor tuning of component values might be advisable.

3.2 Power Supply Switch Section

The LNA power supply switch (Q1 and R1) is controlled by an output pin (GPIO) of the A1080-A GPS receiver. Thus the LNA can be switched off if not needed and power consumption is reduced. This functionality is an integral part of the GPS receiver firmware, no user interaction is needed.

If this functionality is not desired, remove Q1 and R1 and connect the two nodes marked A and B together.

The component used for Q1 (NTSZD3155C [3]) is a complementary MOSFET incorporating an n-channel and a p-channel MOSFET in one single package. It can easily be replaced by two individual parts with similar characteristics.

3.3 Antenna

For footprint recommendations and mounting considerations see the datasheet provided by the antenna manufacturer [4].

4 References

[1] Infineon: Datasheet BGA428, March 2002

[2] Infineon: Application Note 062, A Low Parts Count Low Noise Amplifier for GPS Applications using BGA428, Rev. 2.0, January 2007

[3] ON Semiconductor. Datasheet NTZD3155C, July 2004

[4] Sarantel: Datasheet GeoHelix-P2, 2006

5 Related Information

5.1 Contact

This manual was created with due diligence. We hope that it will be helpful to the user to get the most out of the GPS module.

Anyway, inputs about errors or mistakable verbalizations and comments or proposals to Vincotech, Germany, for further improvements are highly appreciated.

Vincotech GmbH

Bibergerstr. 93
82008 Unterhaching (Munich)
Germany

Tel.: +49 89 8780 67 0

Fax: +49 89 8780 67 351

gps@vincotech.com

www.vincotech.com/gps

5.2 Related Documents

- GPS Receiver A1080 (Vincotech)